



MICRO JIG, INC.

GRR-Ripper® System

INSTRUCTION MANUAL (V4.2SP)

Basic Model GR-100 / Advanced Model GR-200

Read this instruction manual before use and retain it for future reference

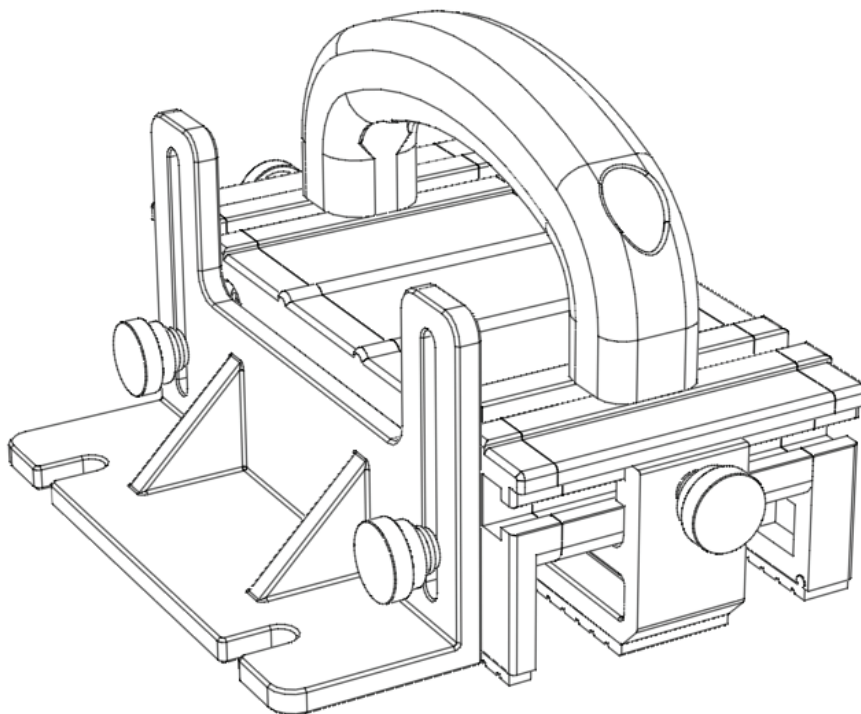

*Made in U.S.A. - US Patent # 7,040,206, other Patent Pending
Copyright © 2001-2008 Micro Jig, Inc.*

WARNING: Operation of the GRR-RIPPER® System includes the use of the a table saw or other tool that is not part of the GRR-RIPPER® System. Micro Jig, Inc. assumes no liability for any product not sold and manufactured by it. The user must take all necessary precautions when operating a table saw or other tools as recommended by their manufacturers or as required by any prudent tool user.

**Micro Jig Building Trades and Home Shop
One Year Limited Warranty**

Micro Jig warrants the GRR-Gripper® System for a period of one year from the date of original purchase. We will repair or replace, at our option, any part or component of the product which fails due to a defect in workmanship or material within the warranty period. This warranty is limited to the first using purchaser and is not transferable. This warranty will exclude any asserted defect or failure caused by normal wear, misuse, neglect, use abuse, improper operation, or any unauthorized service or alteration of the product. Under no circumstances will Micro Jig or any of its affiliates be liable for consequential or incidental damages or other losses or expenses incurred by reason of the use or purchase of this product.

For warranty repair or replacement, send all components/parts of the complete GRR-Ripper® system complete with proof of original purchase to: Micro Jig, Inc. P.O. Box 195607, Winter Springs, FL 32719-5607 Attn: Warranty Service. Please also include a written description of the problem. Allow 4-6 weeks for repaired components or replacement to be shipped from Micro Jig, Inc.

Fill out the table below for your records: -

Model #	GR-100Y (Yellow Handle) <input type="checkbox"/>	GR-100B (Black Handle) <input type="checkbox"/>
	GR-200Y (Yellow Handle) <input type="checkbox"/>	GR-200B (Black Handle) <input type="checkbox"/>
Dealer :		Date of purchase :

*Attach your original receipt here
Warranty and special promotions are available for registered owners only.
Please mail in your Warranty Registration card*

Made in the U.S.A. by: Micro Jig, Inc. P.O. Box 195607, Winter Springs, FL 32719-5607
 Web site: www.microjig.com Email: sales@microjig.com
 (407) 696-6695 FAX (407) 696-6106 Printed in the U.S.A. V4.2SP 05/08

INTRODUCTION TO THE UNIQUE FEATURES OF THE GRR- RIPPER TOOL

The GRR-Ripper® uses grooved non-slip pads to feed and hold down your work piece through the cutting element. The tool can be rotated end-to-end to for use with either the 1/2" or 1/4" Side Leg against the fence.

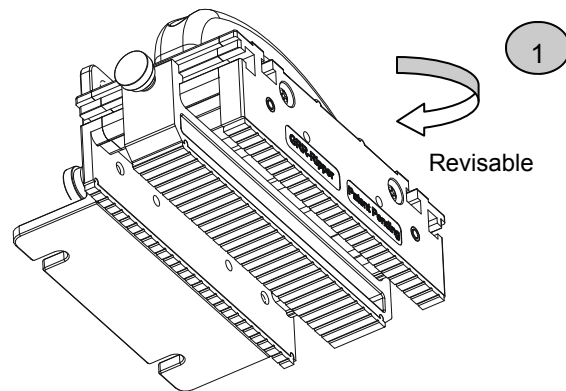

The GRR-Ripper® feeds the work piece as the saw blade passes through either its right or left tunnel. This feature provides protection to both hands of the users. The GRR-Ripper® a protective blade-cover that the user holds regardless of movement.



GRR-Ripper
glides against
Rip Fence

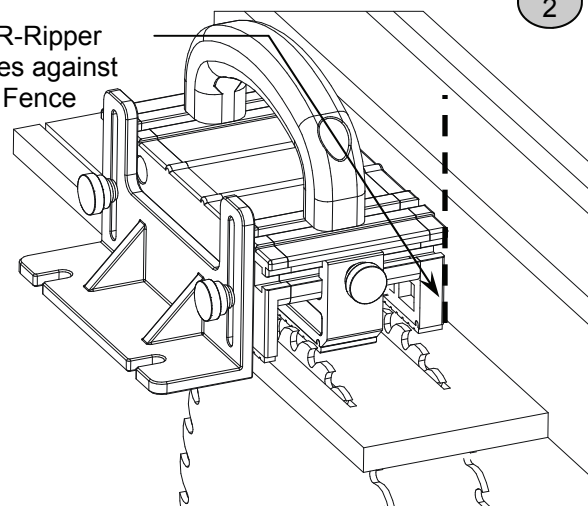

With the rip fence set parallel to the saw blade, The GRR-Ripper® glides against the rip fence to ensure a parallel feed. It also keeps both sides of the work piece in their original positions throughout the cutting process, which minimizes or prevents the possibility of kick back and burning. Bare-hands feeding is therefore eliminated.



The Handle (1) is adjustable to provide balanced and concentrated pressure.



The Balance Support (6) is adjustable in height to accommodate the thickness of the stock.



A wooden spacer can be added for use with stock thicker than 2 inches - attach with # 8 pan head wood screws and washers (not Included).



The Center Leg (3) is adjustable to precisely support the width of cut.



A wooden spacer can be also be added between the GRR-Ripper® and the fence to increase the cutting width capacity of the GRR-Ripper®.

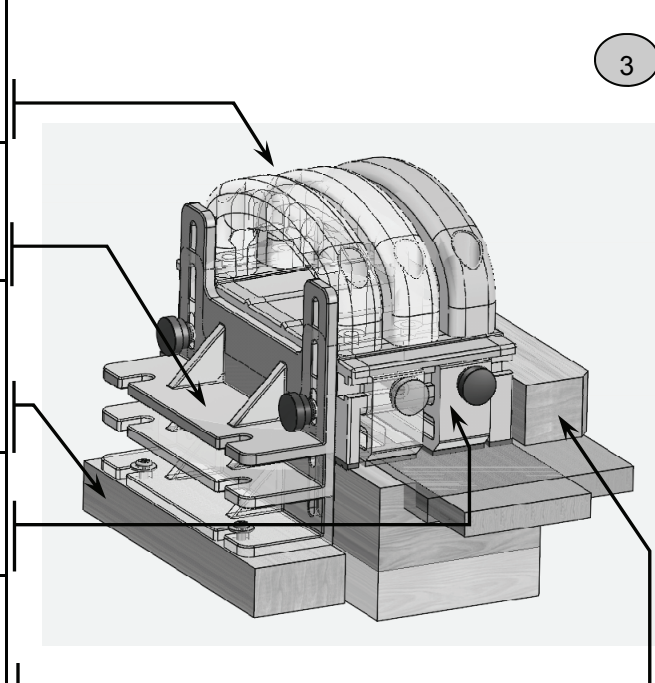

IMPORTANT NOTICE
SAFETY PRECAUTIONS – READ THOROUGHLY BEFORE USE

You must read and agree to the safety precautions and terms listed below before using the GRR-Ripper® System. Your assembly of the GRR-Ripper® System indicates your agreement to follow these safety precautions and terms when using this tool.

- | | |
|---|---|
| <ul style="list-style-type: none"> ◇ All components must be inspected for damage and securely fastened before every use. Stop using the tool if any damage occurs. ◇ In table saw operations, the rip fence must be securely locked parallel to the saw blade within the usable range of the <u>GRR-Ripper® System</u>. ◇ In table saw operation, the face of the Side Leg on the right must be in full contact with the rip fence at all times to order to create a parallel guide for forward feeding and inward pressure against the rip fence. ◇ In table saw operations, the <u>GRR-Ripper® System</u> must be used so it is in full contact with the rip fence at all times, and the saw blade MUST pass through and within the tunnel between two of the legs. ◇ <u>The GRR-Ripper® System</u> includes three legs with non-slip pads. A minimum of two legs MUST be installed during any cutting operation. ◇ Use at least one leg to the right and one leg to the left of the saw blade whenever possible. ◇ Before every cut, the user must look through from the end of the tool after it is in an operational position to make sure the cutter will go through tunnel between legs throughout the entire cutting operation, without touching any component of the tool or other objects except the work piece. ◇ Use maximum possible coverage of the non-slip pads on the work piece. | <ul style="list-style-type: none"> ◇ The <u>GRR-Ripper® System</u> must be used in an absolute stable condition. When a work piece is narrow and is not covered by the leg on the left (away from fence), the Balance Support must be secured to the left leg so the bottom surface of the Balance Support is in full contact with the table top to secure the steadiness of the tool during the entire cutting operation. ◇ The non-slip pads placed on the top surface of work piece must be in full contact with the work piece. The user should frequently inspect the effectiveness of the non-slip pads. Remove built up dust as necessary with denatured alcohol. ◇ The bottom of the work piece must be flat enough so that it does not rock on the table top. The top of the work piece must be flat enough so all non-slip surfaces are in full contact with the top surface of the work piece. ◇ Do not use this tool when any of the components is damaged. Contact your dealer or the manufacturer for replacement parts. ◇ When using this tool in conjunction with any other tool, first read and follow all instructions and safety information in the owner's manual for that tool. ◇ When not in use, store this product on a flat and clean surface. |
|---|---|

Always wear safety glasses and hearing protection. Follow all normal shop safety practices.

<ul style="list-style-type: none"> ◇ Use saw blades that are designed for the intended cutting operation. ◇ When using only one GRR-Ripper®, the user must have both hands on this tool - one gripping the handle, and the other on top of the main body. ◇ The machine tabletop used in conjunction with this tool must be flat and free from obstructions other than the required fence and one cutting element. The tabletop must be reasonably level and below the waistline of operator. ◇ The saw blade must not be set more than 3/4" higher than the top surface of a flat work piece. The ideal height is when the top gullet is slightly above the top surface of the work piece. 	<ul style="list-style-type: none"> ◇ It is the sole responsibility of purchaser of this product to ensure that any third party reads and agrees to all safety precautions and terms prior to their use of this tool. ◇ Do not use this product while under the influence of drugs, alcohol or any medication. ◇ To clean this product, use only denatured alcohol (available from the Paint Department of Home Improvement Centers). <p>IMPORTANT – Never wear loose clothing, gloves, bracelets, or other jewelry that may get caught in the moving parts or cutting elements</p>
--	--

TABLE SAW PREPARATION

- You must have a sturdy and straight rip fence with a flat front surface preferably at least 3 inches in height and square to the table saw top. The rip fence must be long enough to cover the entire depth from the front to the rear of your table saw top. The rip fence must also be equipped with a locking mechanism to secure it on the table saw top so that it is **parallel** to the saw blade at all scale settings. **DO NOT SKEW THE RIP FENCE!**
- The rip fence should also be accurately calibrated to a fixed scale to secure a precise cutting width setting.
- A sharp and clean carbide-tipped saw blade should be used with this tool for ripping, unless otherwise specified.
- A zero-clearance saw blade insert should be always used when cutting narrow strips.

Congratulations! You have just purchased the best and the safest woodworking tool for your ripping operations on the table saw. A cutting-edge 3D solid modeling CAD program was utilized for the precise design of this product. Over 5,000 hours of engineering time and 45 design options and prototypes were developed before we arrived at this final version. Our investment in time and technology will be well rewarded by your satisfaction with this new product.

The **GRR-Ripper® System** comes in two different models, Basic and Advanced. The Basic Model includes six components and the Advanced Model includes eight. Both models provide multiple functionality. The two additional components in the Advanced Model kit provide more convenience and are useful for certain, more advanced cutting operations.

GRR-Ripper® System – Components Identifications

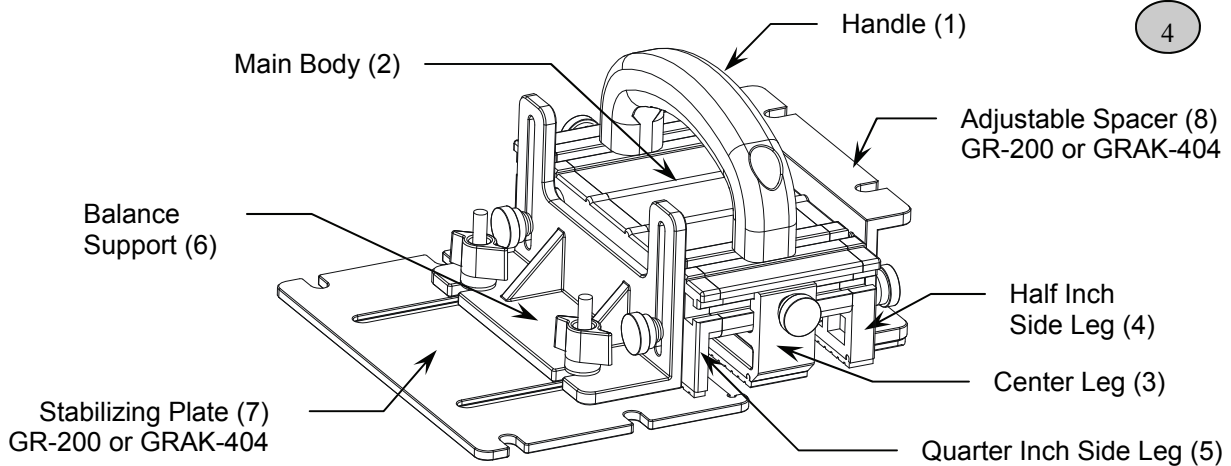

Contents / Color	Model #				Replacement & Upgrade		
	GR-100B	GR-100Y	GR-200B	GR-200Y	RR-303B	RR-303Y	GRAK 404
(1) Handle 1B = One Black	1B	1Y	1B	1Y	-	-	-
(2) Main Body 1Y = One Yellow	1Y	1B	1Y	1B	-	-	-
(3) Center Leg (with non-slip pad)	1B	1Y	1B	1Y	1B	1Y	-
(4) Half Inch Side Legs (with non-slip pad)	1B	1Y	1B	1Y	1B	1Y	-
(5) Quarter Inch Side Leg (with non-slip pad)	1B	1Y	1B	1Y	1B	1Y	-
(6) Balance Support	1Y	1B	1Y	1B	-	-	-
(7) Stabilizing Plate	-	-	1B	1B	-	-	1B
(8) Adjustable Spacer (with non-slip pad)	-	-	1B	1B	-	-	1B
(A) #10 x 7/16" OD washer	8	8	10	10	-	-	2
(B) 1/4 x 1/2" OD washer	4	4	6	6	-	-	2
(C) 9/32" OD O-Ring (#10 screw) Black	6	6	8	8	-	-	2
(D) 5/16" OD O-Ring (1/4-20 screw) Orange	-	-	2	2	-	-	2
(E) 10-32 x 1/2" Thumb Screw	2	2	4	4	-	-	2
(F) 10-32 x 5/8" Thumb Screw	2	2	2	2	-	-	-
(G) 1/4-20 Oval Nut	4	4	4	4	-	-	-
(H) 10-32 Offset Oval Nut	2	2	2	2	-	-	-
(J) 1/4-20 x 1" Pan Head screw	2	2	2	2	-	-	-
(K) 1/4-20 x 3/4" Pan Head screw	2	2	2	2	-	-	-
(L) 10-32 x 1/2" Pan Head screw	4	4	4	4	-	-	-
(M) 1/4-20 x 1 3/4" T-Bolt	-	-	4	4	-	-	4
(N) 1/4-20 Thumb Knob	-	-	4	4	-	-	4
(P) Nylon shoulder washer	-	-	2	2	-	-	2

ASSEMBLY – Basic Model GR-100 Step-by-step assembly is also available on our web site

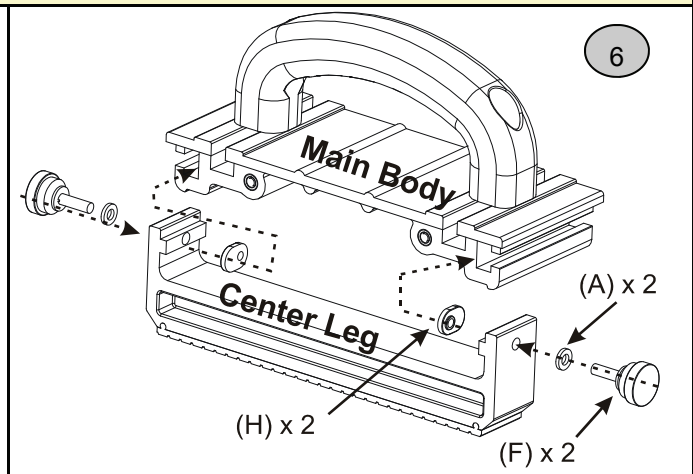
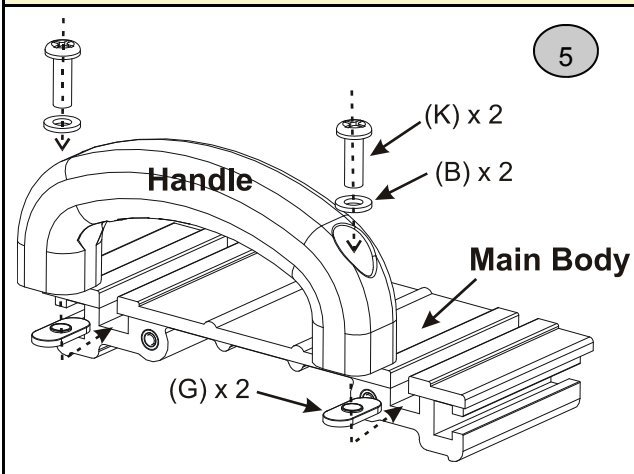

↑ **Step 1:** Assemble Handle (1) to the top slots of Main Body (2).

↑ **Step 2:** Assemble Center Leg (3) to the end slots of Main Body (2).

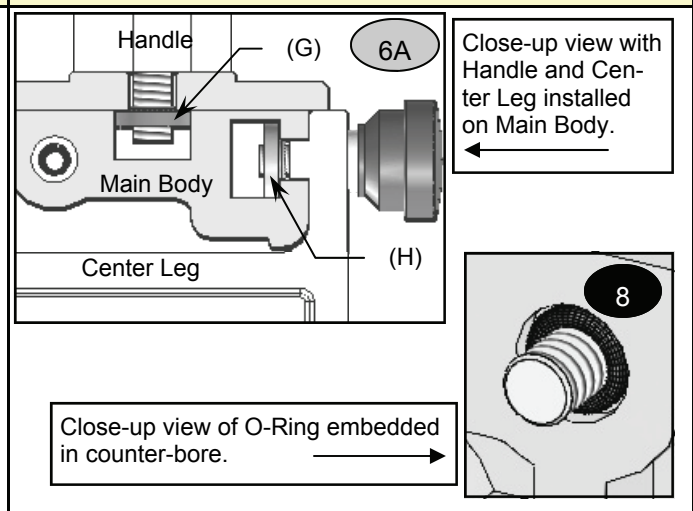
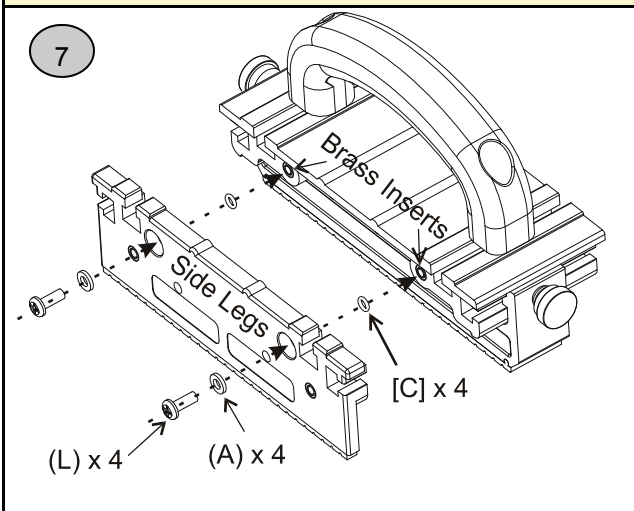

↑ **Step 3 & Step 4:** Install both Side Legs (4) & (5) in the same manner to opposite sides of the Main Body (2). Insert the screws and washers through the front screw holes, insert the O-Rings from the back side. See Figure 8 for detail. **IMPORTANT:** If you purchased the GR-200, do not confuse the Black smaller O-Ring [C] and the Orange larger O-Ring [D].

↑ Fig. 6A shows a close-up view of the hardware locations with the Handle (1) and the Center Leg (3) installed onto the Main Body (2).

↑ Fig. 8 shows O-Ring [C] is installed in the counter-bored hole on the back of the Side Leg, which will serve to retain the hardware when the Side Leg is removed from Main Body for certain applications.

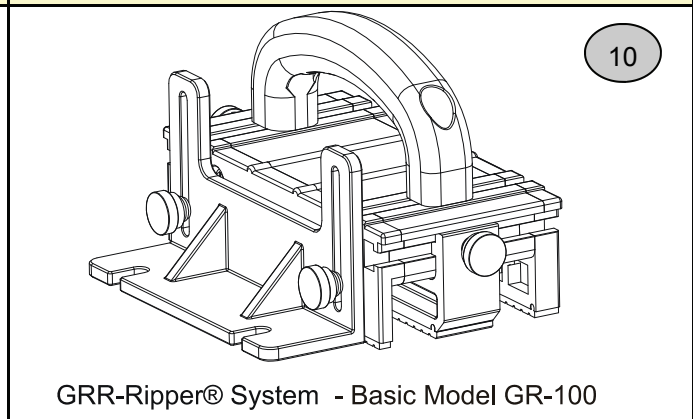
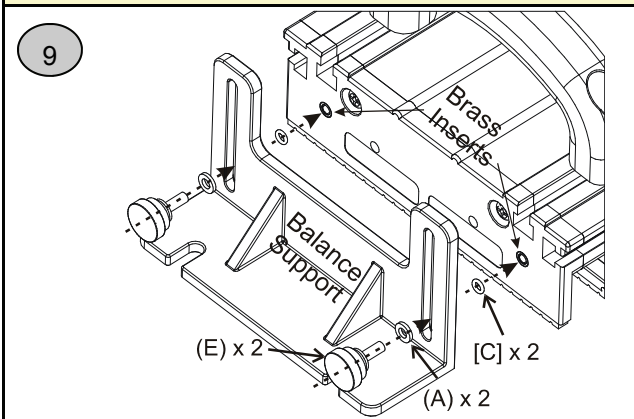

↑ **Step 5:** Assemble Balance Support (6) to either Side Leg (4) or (5).

↑ Basic Model GR-100 completed

Extra hardware left from package - see page 13 & 14 for User-Built accessories.

ASSEMBLY— Advanced Model GR200 = GR100 + GRAK-404

With hardware installed, snap the Stabilizing Plate (7) into the open slots of the Balance Support (6). It is by design that the open slots are narrower than the Shoulder Washer (P), so that the Stabilizing Plate (7) will remain in place during adjustments. The Stabilizing Plate (7) can also be used with its straight edge facing the GRR-Ripper® tool. →

IMPORTANT: Push the Orange O-Ring (D) through the T-Bolt (M) all the way down to contact the Stabilizing Plate (7) before inserting the Shoulder washer (P) and the Thumb Knob (N).

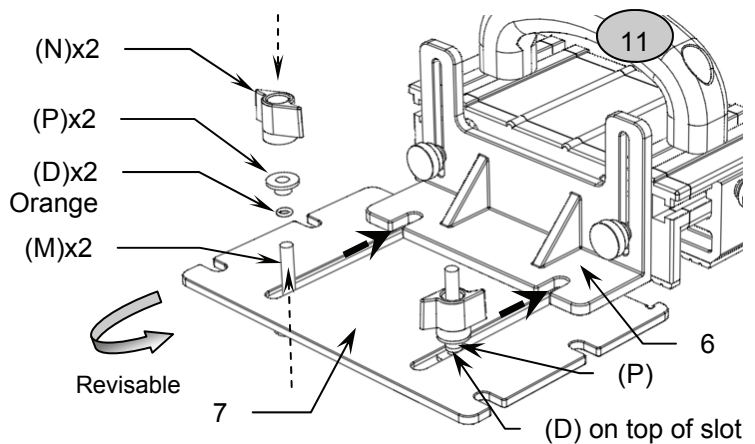

The Adjustable Spacer (8) can be attached to either Side Leg - on the right or the left. It can be used with the non-slip pad downward to provide an additional level pressure surface. Lower it to achieve two levels of pushing surfaces. It can also perform as a “balancing device” with the non-slip pad facing upward. →

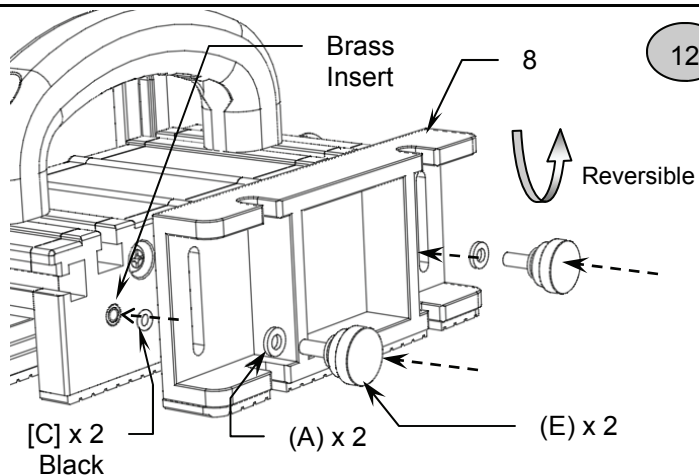

Advanced Model GR-200 completed. →

There will be some extra hardware left after the assembly is completed. They are for User-Built accessories shown on page 11, 13 & 14 that you can build if you like to further expand the capability of the GR-200 model.

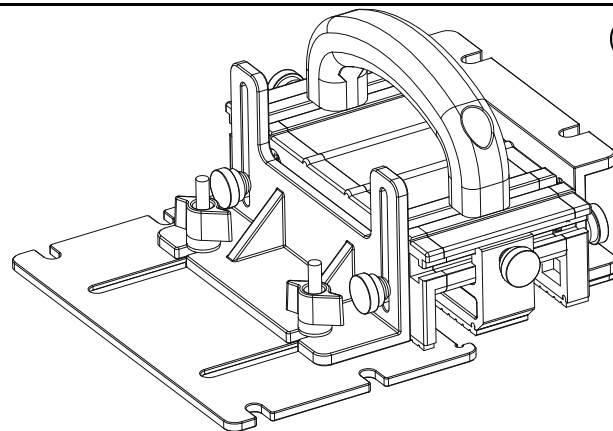

GRR-Ripper® System - Advanced Model GR-200

IMPORTANT: Keep the Non-Slip Pads Clean!

To keep the non-slip pads working most effectively, clean the contact surfaces with **denatured alcohol** and a shop rag prior to use. Repeat cleaning during use as necessary when sawdust accumulates. Denatured alcohol is available from the paint department of home improvement centers.

Techniques for using GRR-Ripper® System

- The GRR-Ripper® System is designed to glide along with rip fence of a table saw, so the rip fence must be **parallel** to the saw blade in order to maintain the parallel feed.
- Saw blade should be raised just enough in height to clear the gullets from the top surface of wood pieces; normally about 1/4" to 3/8". Pay extra caution on work pieces that are not equal in thickness such as tapered stock. The tunnel has a clearance of 15/16" in height.
- The saw blade must pass through the adjustable tunnel and in between the legs for maximum safety. Always sight through from the end before turning on your saw to make sure that the saw blade would not cut into any component of the tool.
- When using one single GRR-Ripper®, both hands should be used on the tool. Place one hand in the inclined position and grip the Handle (1). Place the other placed on the top of Main Body (2) to provide added pressure against the rip fence, additional forward feeding pressure and firm downward on work piece. **WARNING:** NEVER feed stock using bare hands when using the GRR-Ripper®.
- The Handle (1) can be secured at an angle in relation to the Side Legs (see figure 17), an "automatic" pressure will be exerted against the fence when the tool is pushed forward.
- For best cutting result, use one non-stop feed from start to finish - do not pause during the cutting operation. Push work piece completely clear of saw blade, stop the motor, and wait for the saw blade to come to a complete stop before releasing pressure from the work piece.
- The non-slip pads are molded from Thermal Plastic Elastomers and will slightly compress when downward pressure is applied. When setting the height of Balance Support (6), it is best to set the non-slip pads over work piece, put normal downward pressure from Handle (1), lower the Balance Support (6) until it fully contacts the table saw top, then secure Balance Support (6) in that position before releasing pressure from Handle (1). Double check the setup by applying downward pressure on the tool with one hand and slightly pulling the work piece under the tool. If not enough contact pressure either in the front or rear, adjust the Balance Support (6) accordingly.
- Depending on your table saw model, the GRR-Ripper® System should be placed about 1 " to 4" from the trailing end of work piece (see figure 25), otherwise, the tool will be off the table saw top at rear before work piece will be clear of the saw blade.
- If work piece is longer than 16", the use of two GRR-Ripper® System is recommended - see figure 25 for connecting two GRR-Rippers® or use "leap-frogging" technique for cutting stock of unlimited length .
- If width of cut is between 1/4" to 5/8" on the "Inside Cut", use Quarter-Inch Side Leg (5) on the right against the rip fence. If width of cut is less than 1/4", it should be obtained from "Outside Cut" as shown in figure 15. One advantage of using the GRR-Ripper® System for cutting thin strips over the conventional push block method is the width of your prepared stock on "Inside Cut" area is substantially reduced. Yield is greatly increased by saving material, thus reducing costs. Most important, the saw blade is always within the tunnel, which provides protection for your fingers.
- For a wider inside cut that is beyond the limits of the GRR-Ripper® System, wooden spacers of various widths can be added to the Side Leg against the fence (see figure 3). You may drill a couple of counter bored holes (5" center-to-center) for 10-32 pan head screws and secure it to the brass inserts on the Side Legs. Alternatively, you can use #8 pan head wood screws from the inside wall of the 1/2" Side Leg (4).

WARNING: The following is a necessary precaution!
Before turning on the saw, always site through from end to make sure there is enough clearance for saw blade to pass through the tunnel safely.

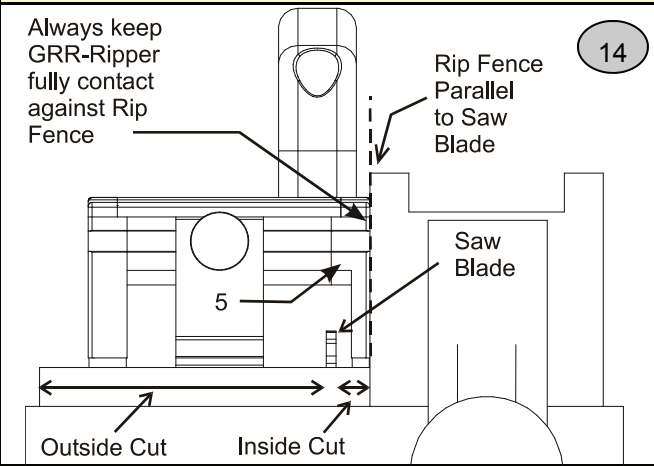

Always keep GRR-Ripper fully contact against Rip Fence

Rip Fence Parallel to Saw Blade

14

5

Saw Blade

Outside Cut

Inside Cut

↑ 1/4" Leg (5) against the fence for cutting width (inside cut) of 1/4" to 5/8". Note the location of the Handle (1) above the cut line in order to apply balanced pressure to both sides of the stock.

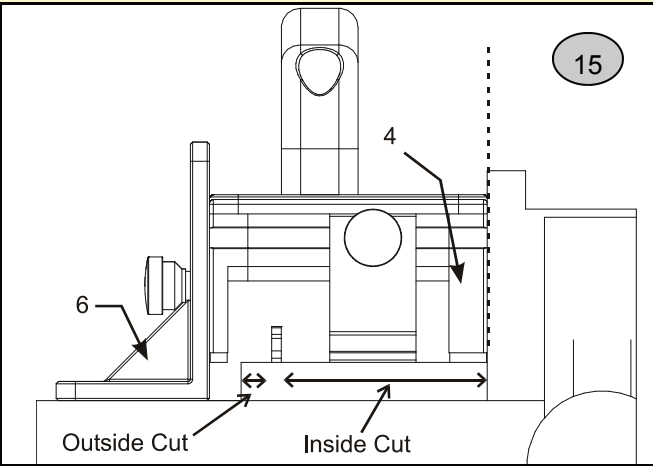

15

4

6

Outside Cut

Inside Cut

↑ 1/2" Leg (4) against the fence for cutting width (inside cut) from 5/8" to 3 3/16". Use the Balance Support (6) when stock is not wide enough to be under the Side Leg on the left. The Handle (1) is secured more towards the right side of saw blade since no pressure is required on the left side of the cut.

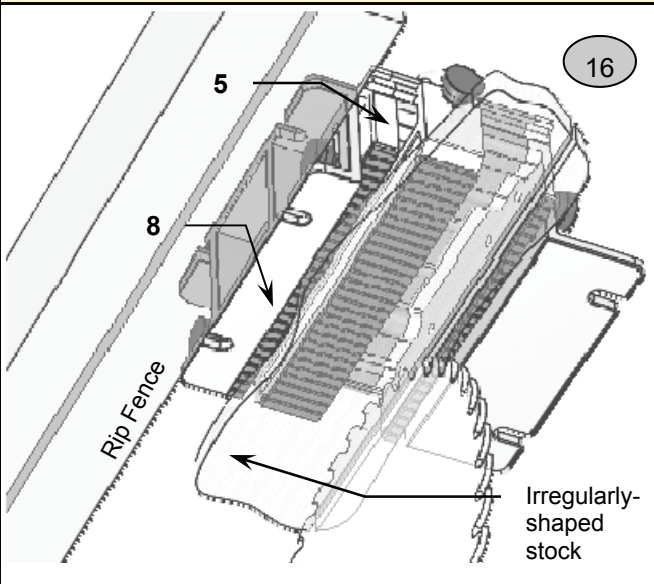

16

5

8

Rip Fence

Irregularly-shaped stock

↑ This is a translucent bottom view with the table saw top removed for clarity. The GRR-Ripper® GR-200 is feeding irregularly-shaped stock to obtain a straight edge. Notice the Half Inch Leg (5) does not cover the stock edge completely. The Adjustable Spacer (8) is used with the smooth side down and leveled with table top to prevent the tool from tipping over and to glide against the rip fence for a parallel feed.

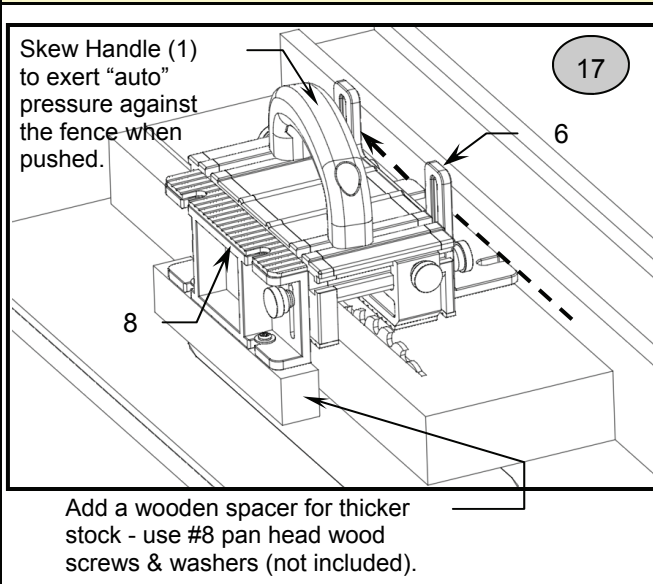

17

Skew Handle (1) to exert "auto" pressure against the fence when pushed.

6

8

Add a wooden spacer for thicker stock - use #8 pan head wood screws & washers (not included).

↑ Using Balance Support (6) against fence will provide an additional 2" of cutting width. The Adjustable Spacer (8) - (GR-200) can be used on the left as a "balancing device".

Note: All table-saw illustrations in this Instruction manual show a 1/8" kerf saw blade and a rip fence that is secured parallel and to the right of saw blade.
 Inside Cut = Cut between rip fence and the saw blade, it is usually the keeper piece.
 Outside Cut = Cut on the left side of saw blade, it is usually the off-cut piece.

Jointing - With a simple user-built Jointing Bridge, jointing the rough edge of your stock is just a one-pass operation on a table saw. This operation can only be performed with GR-200 or GR-100 and Attachment Kit GRAK-404.

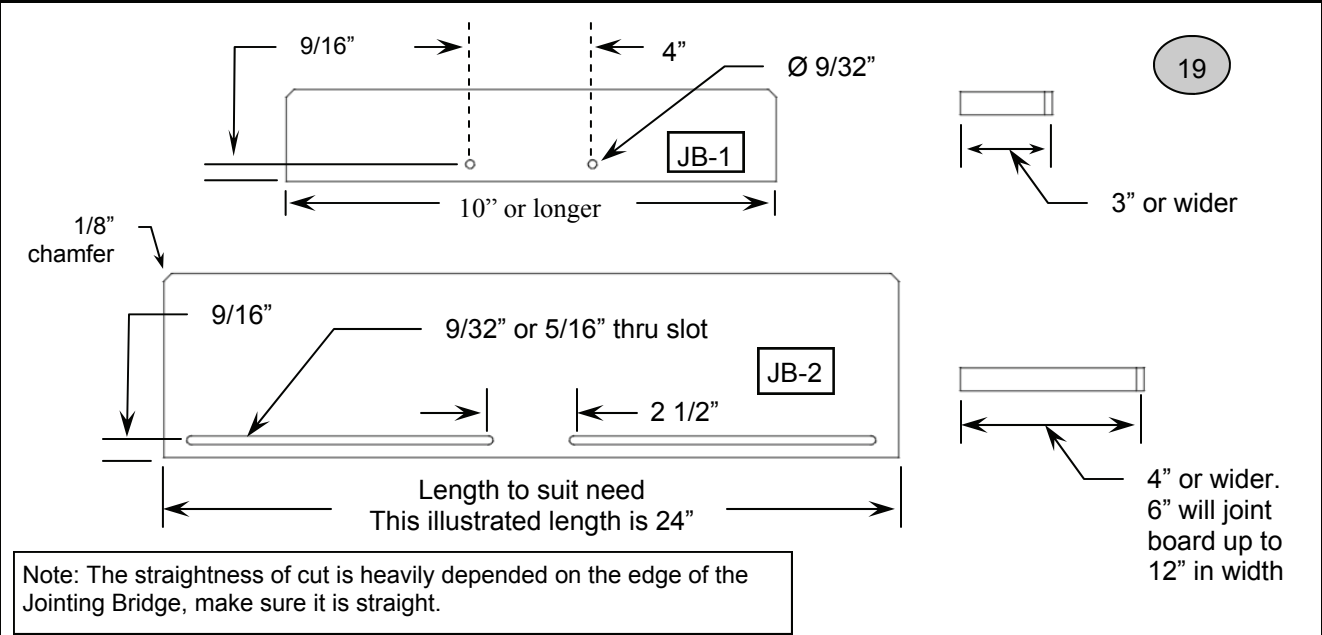
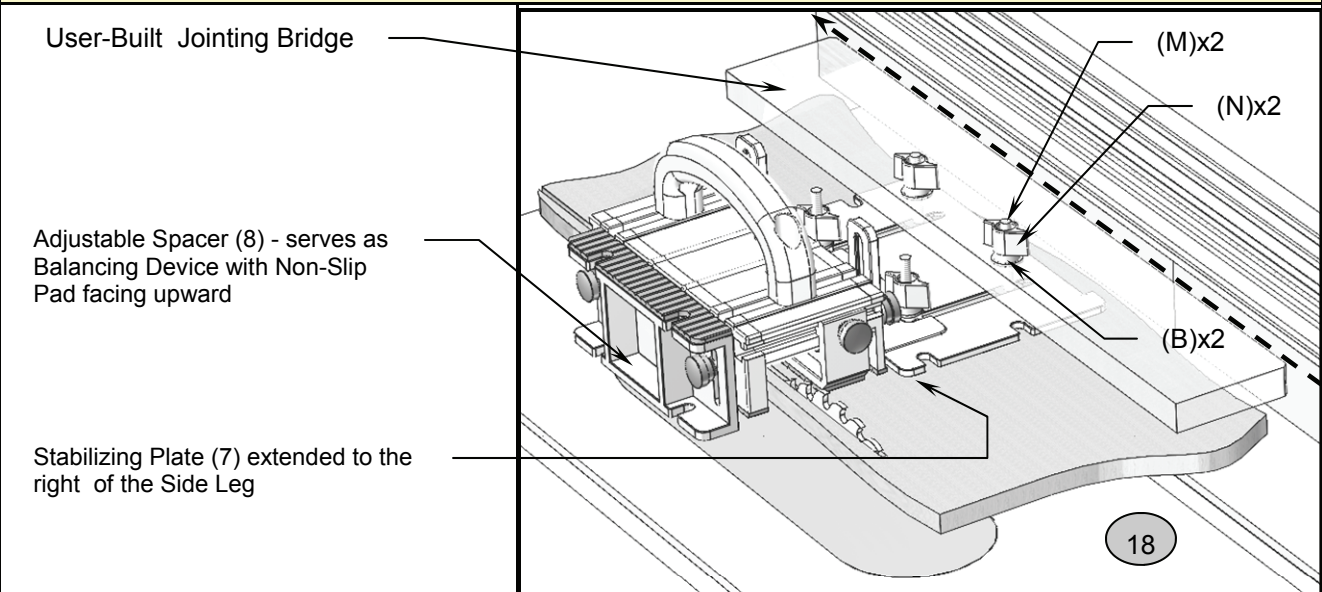

↑ For Single GR-200 (short stock):
Build the Jointing Bridge (JB-1) shown on the top of Drawing 19. Use 3/4" thick plywood. The specified Hardware is included with each GR-200.
(B) x 2 (M) x 2 (N) x 2

Suggestion: You may build several Jointing Bridges of different widths to increase the cutting capacity of the GRR-Ripper® for regular ripping.

↑ For two or multiple GR-200s (longer stock):
Build the Jointing Bridge (JB-2) shown at the bottom of Drawing 19. Use 3/4" thick plywood. The specified hardware is included with each GR-200.
(B) x multiple of 2 (M) x multiple of 2 (N) x multiple of 2

Cut one thru slot for every GR-200. You must have at least one GR-200 pushing the stock on the table top throughout the cutting operation. A width of at least 4" is required for a JB-2 that is longer than 24" in order to maintain the strength.

For long boards, level support tables/rollers should be used both at the in-feed and out-feed ends of the table saw .

Resawing : You can resaw narrow stock in one pass without a bandsaw, planer or flat-bed sander. Note: Stock must be square before resawing. ↓

Resaw to 1/4" (inside cut) or thicker in one pass as shown in Drawing 20. Note Handle (1) location. →

Resawing stock thinner than 1/4" or re-sawing wider stock, can be achieved in two passes by setting the saw blade slightly higher than one half of the width of the stock in the first pass. Flip the stock over and finish with a second cut.

Suggestion: Resawing stock thinner than 1/4" should be obtained from the outside cut.

A wooden spacer can be added to the Balance Support (6) for stock wider than 2" (see Drawing 3).

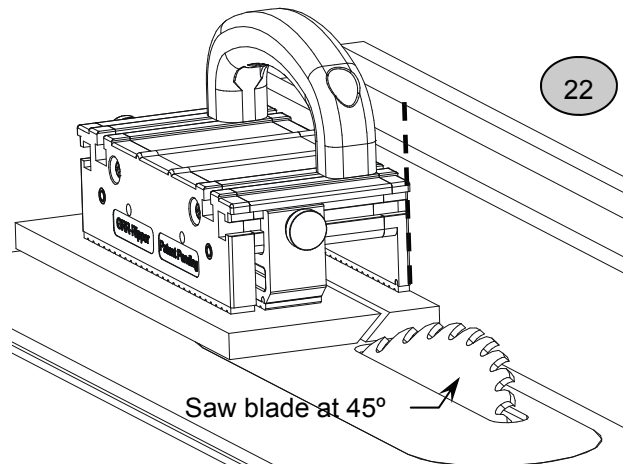
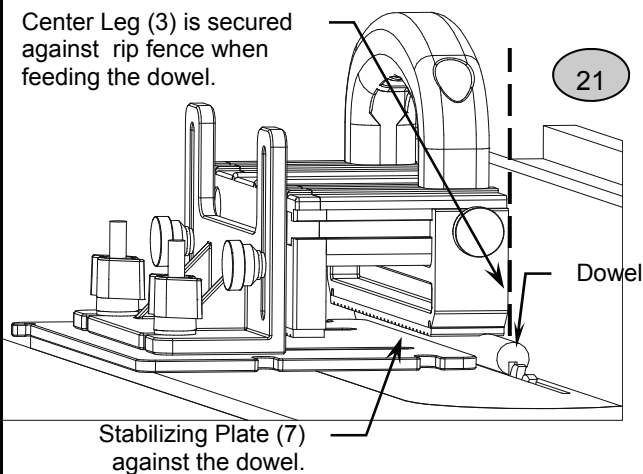
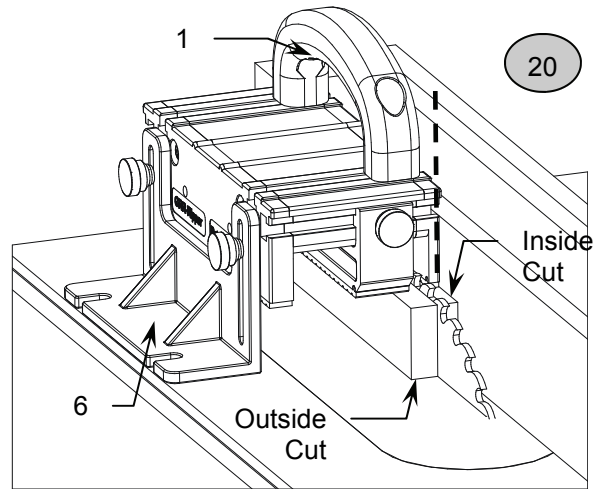

↑ **Grooving a round dowel** - With one of the Side Legs removed, the Center Leg (3) is registered against the rip fence, and the Stabilizing Plate (7) of a GR-200 holds the dowel against the rip fence. You can also make a wider groove on the router table (see details on our web site.)

↑ **Bevel Cuts** from 0 to 45 degrees - great control and eliminates binding. Moving the rip fence to the left side of the saw blade is no longer necessary on a right tilting table saw.

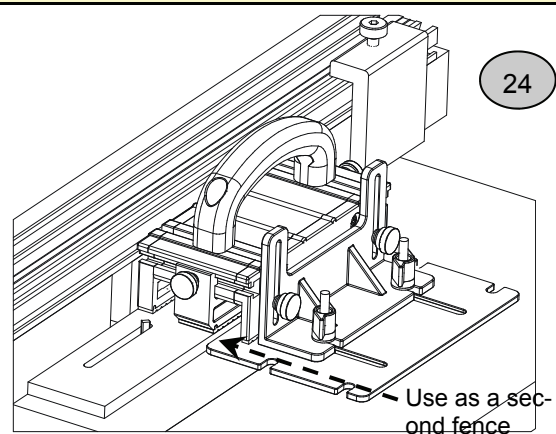
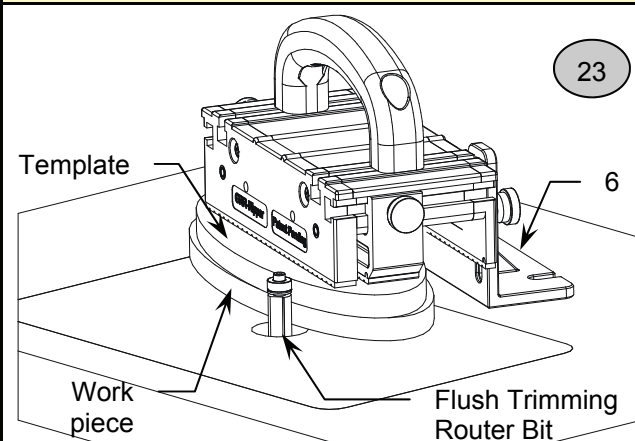

↑ **Pattern Routing** - Securely holds and guides a small work piece against a template without tipping over.

↑ **Slotting** - Use the Stabilizing Plate (7) of the GR-200 as a second fence to box-in the work piece.

While one GRR-Ripper® tool is best for stock under 16" in length, two or more GRR-Rippers can be connected together for longer boards. ↓

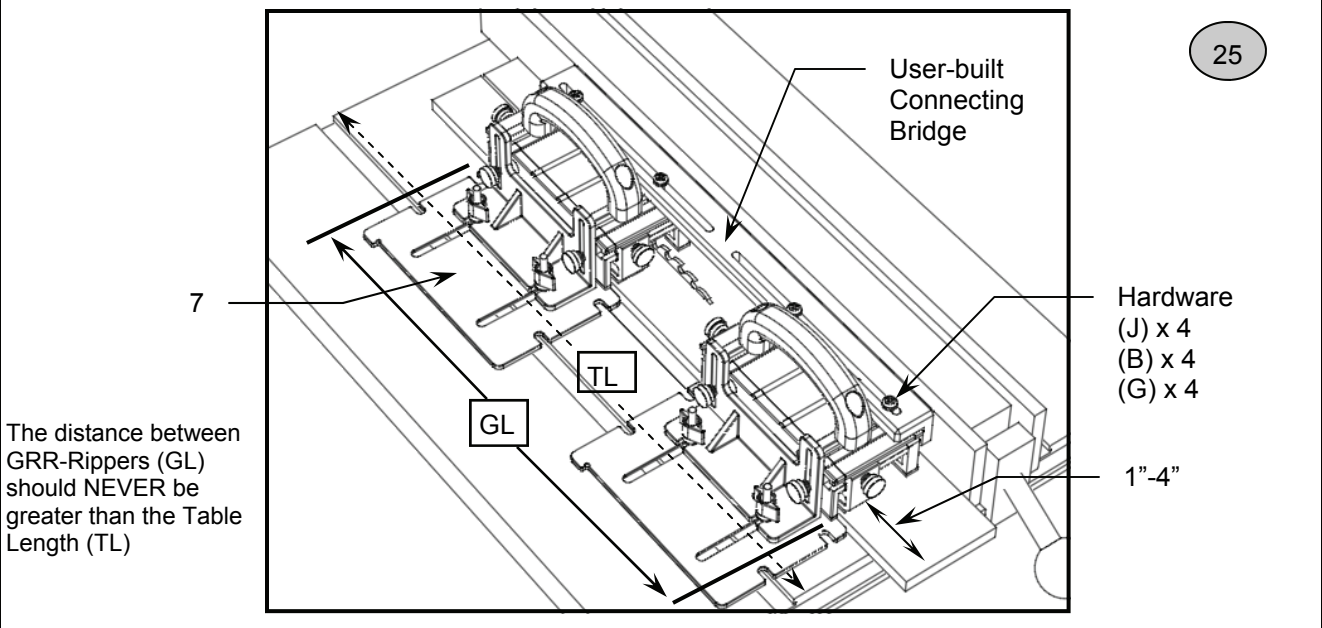

The use of Stabilizing Plates (7) provide more control for longer stock. ↑

Connecting Bridge - Construct from one piece solid hardwood

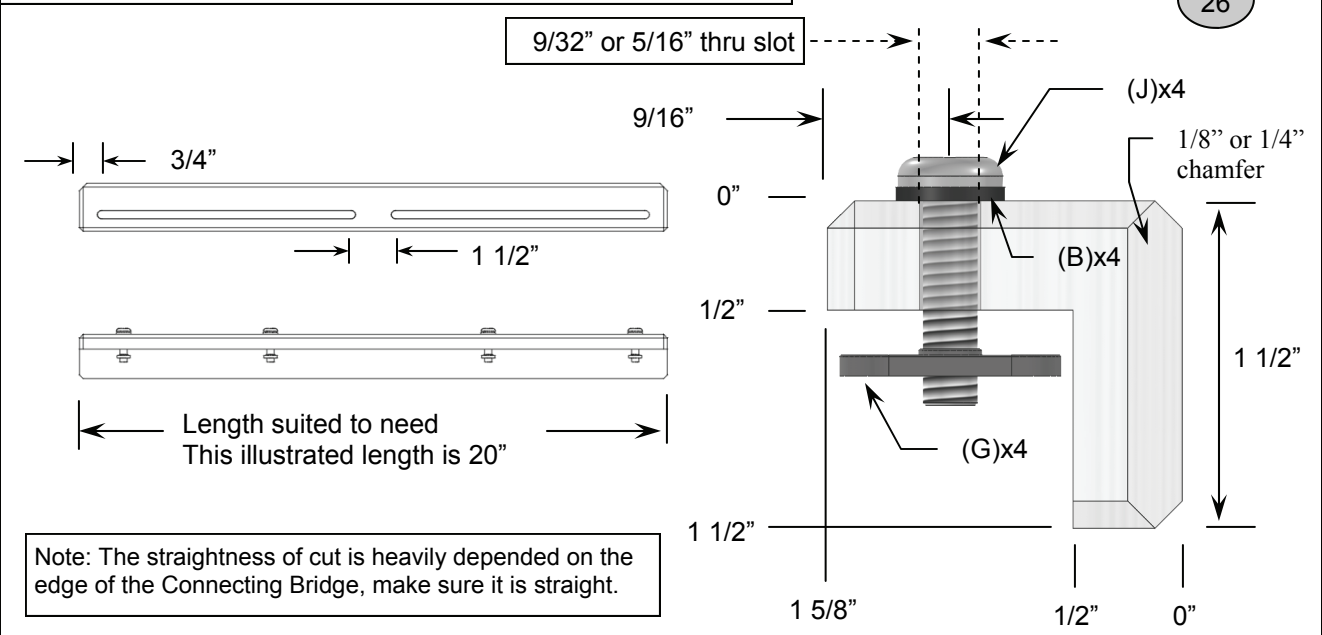

The connected GRR-Rippers are intended for ease of controlling repeated cuts of similar lengths.

WARNING: All user-built accessories illustrated in this manual are intended to serve only as a guideline. Improperly-made accessories or the use of inappropriate hardware may cause injuries. Always make sure accessories are properly and securely fastened before their use. All hardware for suggested user-built accessories are included with the GRR-Ripper® Systems - except # 8 pan head wood screws and washers for user-built wooden spacers used under the Balance Support (6) and the Adjustable Spacer (8).

Full Profile Edge Routing - GRR-Ripper® allows you to get full profile cuts without fine adjustments or shimming fences on your router table.

Side Leg on right removed for clearance of router bit. A user-built L-Shaped Spacer (optional) is used.

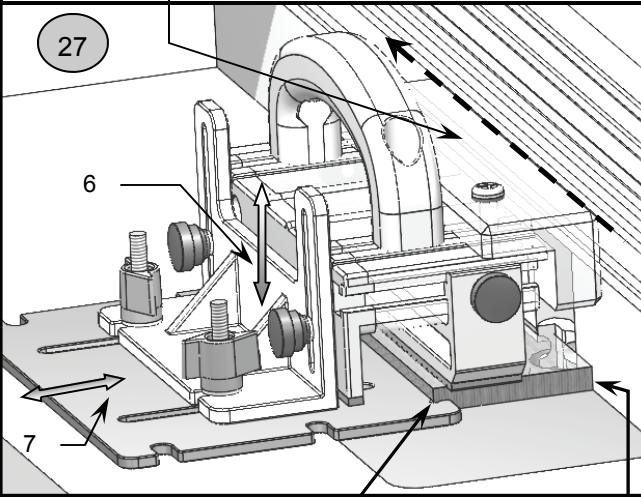

Adjust (7) against work piece with hook at trailing end

Work piece against In-feed fence before cutting

User-Built L-Shaped Spacer prevents Main Body (2) from engaging the T-slot of Fence

Out-Feed End View ↓

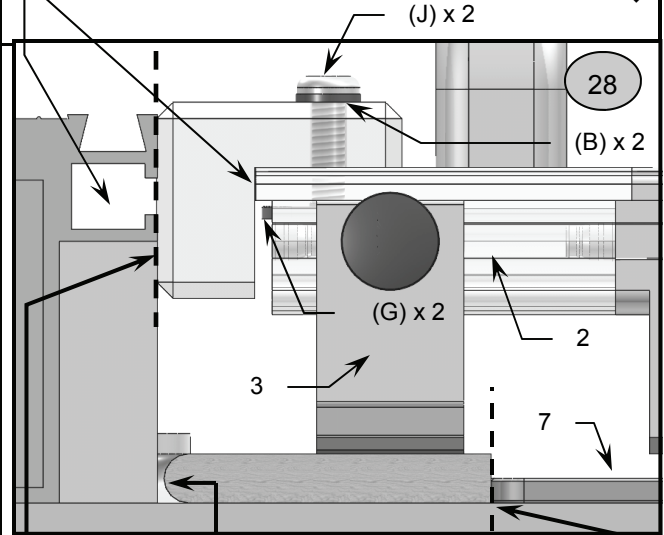

L-Shaped Spacer prevents snipe on work piece.

Stabilizing Plate (7) prevents work piece from shifting outward.

1. Do not offset split fences. Set fence to allow the full profile of the router bit to be exposed as shown in drawing 28. Dimension stock on the table saw after the profile is obtained.
2. Place stock with its edge against the in-feed fence. Adjust the Center Leg (3), Balance Support (6), and Stabilizing Plate (7) as shown in drawing 27. The narrow work piece should be completely boxed-in while the L-Shaped Spacer is in full contact with the fence.

User-Built L-Shaped Spacer (One piece solid hardwood)

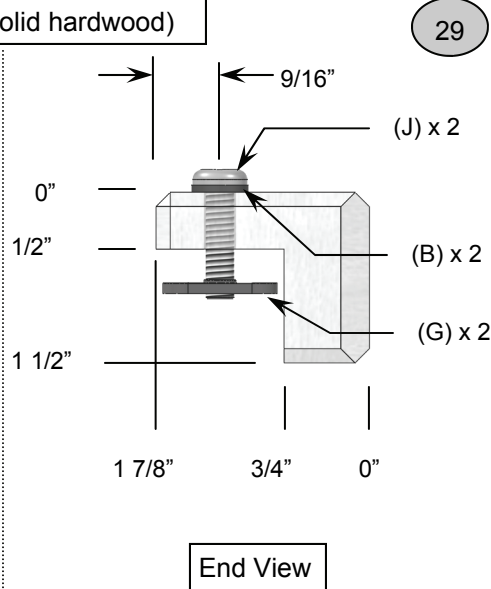
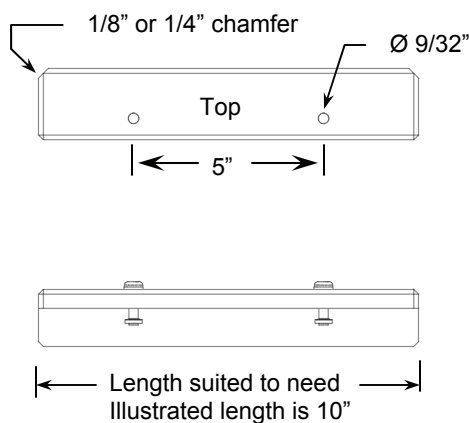

An L-Shaped Spacer provides better control when the Side Leg on the right is removed, and is recommended when the fence has an open T-Slot on its front surface. An L-Shaped Spacer can also be used on the table saw to increase the cutting width by 3/4\" (avoid the saw blade cutting into the Side Leg on the left when the cutting width is between 3 1/4\" to 3 3/4\").



If you own two or more GRR-Rippers and are building both this L-Shaped Spacer and the Connecting Bridge in drawing 26, you need to share the hardware or obtain an extra set of hardware.

DVD

The GRR-Ripper® System is an extremely versatile tool capable of endless configurations and applications that simply can not be illustrated entirely in this manual. A DVD Instructional Video is available with over 30 different applications that are demonstrated by five most distinguished woodworkers and authors. The following photos exhibit some of the contents within this feature-packed two hour video. Ordering information can be found on the back cover of this manual.

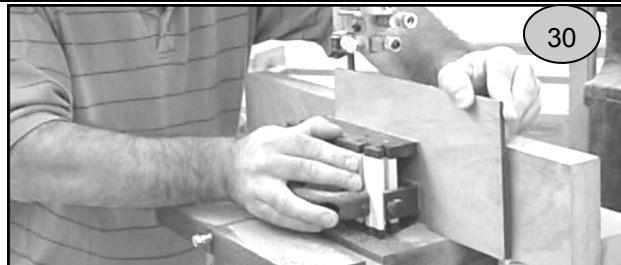

30

↑ The GRR-Ripper provides great control when resawing veneer on the band saw, and allows for getting more yield out of your stock. The video also demonstrates the use of the GRR-Ripper® on the jointer.

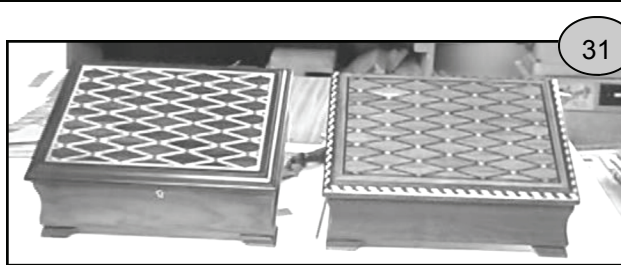

31

↑ Look at these beautiful jewelry boxes! The DVD shows you how the GRR-Ripper® controls thin veneer on the table saw and allows you to perfectly dimension even fussy diagonally cross-cut geometric patterns. The video also shows you how to rip thin strips of solid surface material including with a neat trick to prevent slippage - an almost impossible task without the GRR-Ripper®.

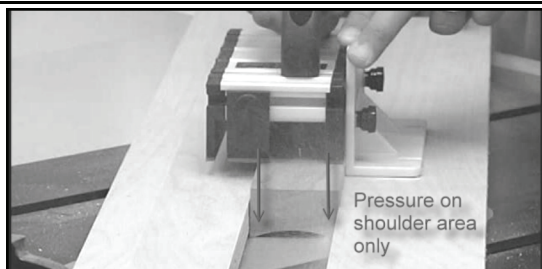

32

↑ The GRR-Ripper® is adjusted to apply downward and feeding pressure only on the two shoulders during a cove cutting operation on the table saw. This greatly reduces the danger of applying too much pressure at the center of the work piece when done the conventional way.

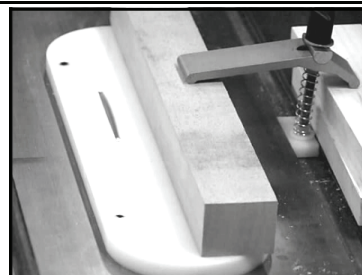

33

↑ An included bonus is how to simplify the process of preparing a zero clearance insert (ZCI) for the table saw. A ZCI is an essential accessory for safer and finer woodworking results.



34

↑ Some woodworkers prefer a hook at the trailing end, especially when feeding unevenly-surfaced stock. The video shows a wood block that is very easy to make. It is simply slipped into the rear slot of the GRR-Ripper®.

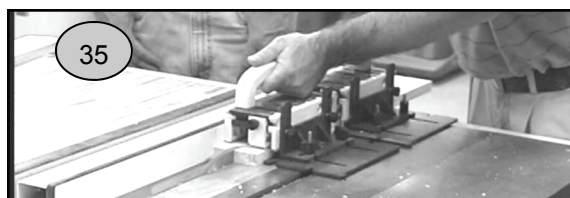

35

↑ Our professional team also demonstrates how to rip long stock of unlimited length by using two GRR-Rippers in a "leap-frogging" technique.

Our professional team in the video includes (listed alphabetically):

Paul Anthony - Professional woodworker, editor, teacher, and author of the award-winning Home Storage Projects (Taunton Press, 2002) and Smart Workshop Solutions (Taunton Press, 2003.)

Craig Bentzley - Lecturer and author of many articles featured in Popular WW, AW magazine, and several Rodale Press publications.

Ken Burton - M.F.A. Rochester of Technology, principal of Windy Ridge Woodworks, and author of Cutting Edge Table Saw Tips & Tricks (F&W Publications, 2003)

Chris DeHut - The Executive Producer and Host of Woodworking At Home Magazine (DVD format.)

Adolph Schneider - Traditionally-trained European craftsman, professional cabinetmaker in the US for over 40 years , specializes in veneer inlay work.

**Accessories Order Form – Make a photo copy, fill out and mail to Micro Jig, Inc.
Phone/Credit card order— Call 1-407-696-6695 Visa, Master Card or American Express**

GRR-Ripper Accessories and Replacement Parts

(Free shipping within 48 contiguous states in USA, excluding Alaska & Hawaii)

Part #	Descriptions	Unit price	Qty order	Extend Total
GR-DVD1	GRR-Ripper® System Instructional Video—DVD only Over two hours of actions—Five professional woodworkers/ authors demonstrate over 30 different cuts and techniques - a must see!	\$9.95		
GRAK-404 (See page 6)	Attachment Kit (upgrade GR-100 to GR-200), includes Stabilizing Plate (7) – Black only Adjustable Spacer with green non-slip pad (8) – Black only Required hardware (HW-GRAK-404)	\$26.95		
RR-303Y	Yellow Replacement Legs Set, includes Yellow Center Leg with green non-slip pad Yellow 1/2" Side Leg with green non-slip pad Yellow 1/4" Side Leg with green non-slip pad	\$28.95		
GRP-3Y	Yellow Center Leg with green non-slip pad	\$13.95		
GRP-4Y	Yellow 1/2" Side Leg with green no-slip pad	\$11.95		
GRP-5Y	Yellow 1/4" Side Leg with green non-slip pad	\$11.95		
RR-303B	Black Replacement Legs Set, includes Black Center Leg with green non-slip pad Black 1/2" Side Leg with green non-slip pad Black 1/4" Side Leg with green non-slip pad	\$28.95		
GRP-3B	Black Center Leg with green non-slip pad	\$13.95		
GRP-4B	Black 1/2" Side Leg with green no-slip pad	\$11.95		
GRP-5B	Black 1/4" Side Leg with green non-slip pad	\$11.95		
GRP-1Y	Yellow Handle with hardware - excellent for shop jigs	\$11.95		
GRP-1B	Black Handle with hardware - excellent for shop jigs	\$11.95		
Sub-Total				
Florida residents add 7% sales tax				
Total				

Shipping & Credit Card information (Visa, Master Card, American Express or pay by check)

Name:							
Address:							
City:		State:		Zip:		Country:	
Telephone #:	Req'd if paying by credit card (_____) _____ - _____				Email:		
Credit Card #					Exp. Date:		

To order: Mail a copy of this order form with a check for the total amount or credit card information to:
Micro Jig, Inc., PO Box 195607, Winter Springs, FL 32719-5607, or call 1-407-696-6695 for credit card orders.
Note: Prices and specifications of accessories and parts are subject to change without notice.
Free shipping (on Accessories items only) is offered by direct order through Micro Jig, Inc. only!

New product - Introduction

MJ Spli+++er™

A low profile splitter for Zero Clearance Insert
Model SP-0125 - For 1/8" saw blade
Model SP-0100TK - For Thin Kerf saw blade
Four alignment surfaces for different effects
Fool proof installation with Drill Guide
For 90° cut only
Made in USA - patent pending

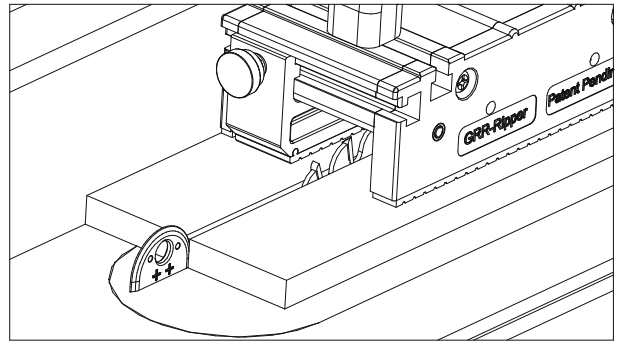

Another breakthrough invention from Micro Jig, Inc. Ours is a low profile splitter that also serves as a mini feather board for the keeper piece behind the saw blade. **Simple, exact** and **extremely effective**, cutting results are exceptionally precise and virtually burn free when using the MJ Splitter. It is designed to be used on a Zero Clearance Insert (ZCI) with or without the GRR-Ripper® System. The MJ Splitter features fool proof installation and a revolutionary concept that provides alignment surfaces of different thicknesses. This allows you to fine-tune your application by choosing the best surface to suit your immediate requirements.

The MJ Splitter is made out of unbreakable polycarbonate, a plastic material with inherent characteristics that create the feather board effect when desired. The MJ Splitter is engineered so that it will never run out of its intended alignment.

Note: Any splitter behind the saw blade has no effect on the stock until the stock's leading edge passes the splitter. The use of the GRR-Ripper® System in conjunction with the MJ Splitter will not only ensure parallel feeding of your stock before it reaches the splitter, it will also provide protection to both of your hands.

MJ Splitter package contents

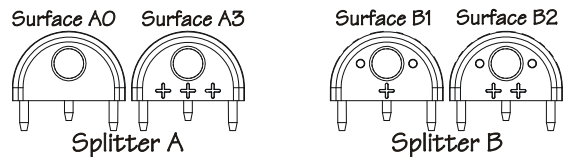
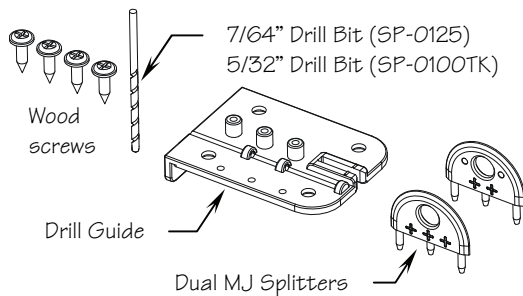

Each MJ Splitter Kit comes with two Splitters - with total of four different alignment surfaces. In use, each additional "+" sign indicates that surface extends 0.003" (SP-0125) or 0.002" (SP-0100TK) ± closer to the fence than the surface that has one less "+" sign. This option also allows you to select a surface that protrudes slightly into the left edge of the keeper piece by thousandths of an inch, which generates slight tension - like a mini feather board - behind the saw blade.

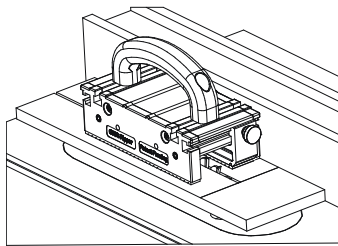

Fool proof installation

Create a stopped saw kerf on a setup board.

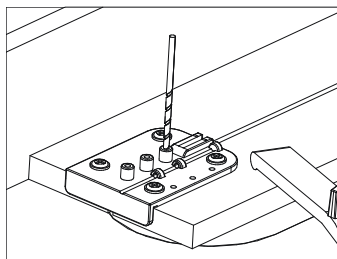

Insert Drill Guide into saw kerf and drill perfectly aligned installation holes.

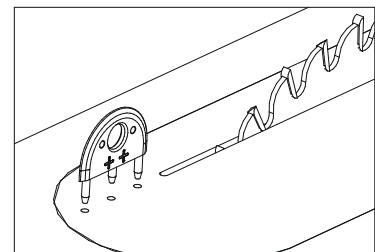

Push in the MJ Splitter - test and select the surface that best suits your preference.

Illustrations shown with Model SP-0125 (1/8" Kerf). Note: Due to more the sophisticated engineering required to enable new innovative concepts, Model SP-0100TK (Thin Kerf) is slightly different in appearance.

For more information on the MJ Splitter, please visit our web site at www.microjig.com.

To order the MJ Splitter - Check with your favorite woodworking supplier for availability, or Order directly from Micro Jig, Inc. - See the Order Form on page 18 or call (407) 696-6695.

**Order Form – Make a photo copy, fill out and mail to Micro Jig, Inc.
Phone/Credit card order— Call 1-407-696-6695 Visa, Master Card or American Express**

GRR-Ripper and MJ Splitter Order Form

(Shipping & Handling quoted are for 48 contiguous states in USA, excluding Alaska & Hawaii)

Part #	Descriptions	Shipping & Handling per unit	Unit price	Qty order	Extend Total Not including shipping
SP-0125	 MJ Splitter for 1/8" saw blade List price \$24.95 Limited time Offer Sale \$19.95	\$2.00 (by mail within US)	\$19.95		
SP-0100TK	 MJ Splitter for Thin Kerf saw blade List price \$29.95 - Limited time Offer Sale \$24.95 Exciting new concept—visit our web site for details on how to set up double TK MJ Splitter for simultaneous use on both sides of stock.	\$2.00 (by mail within US)	\$24.95		
GR-100	GRR-Ripper® System - Basic model	\$8.75/first unit \$2.50/2nd unit	\$49.95		
GR-200	GRR-Ripper® System - Advanced Model	\$9.75 /first unit \$3.00/2nd unit	\$69.95		
GR-DVD1	 GRR-Ripper® System Instructional Video— DVD only	Free Within US	\$9.95		
	Add accessories (from page 16) here				

Sub-Total		
Shipping & Handling		
Total		
(7% of the Total amount)	Florida residents add 7% sales tax	
Grand Total		

Shipping & Credit Card information (Visa, Master Card, American Express or pay by check)

Name:							
Address:							
City:		State:		Zip:		Country:	
Telephone #:	Req'd if paying by credit card (____) ____ - ____				Email:		
Credit Card #	_____ - _____ - _____ - _____				Exp. Date:	___ / ___	
Security code :	_____			Visa & M.C - last 3 digits on the back A.E. - 4 imprinted digits on the front			

To order: Mail a copy of this order form with a check for the total amount or credit card information to:
Micro Jig, Inc., PO Box 195607, Winter Springs, FL 32719-5607, or call 1-407-696-6695 for credit card orders.
Note: Prices and specifications of our products are subject to change without notice.